

3b Wiring the OzLine 12CS Using Auxiliary Outputs

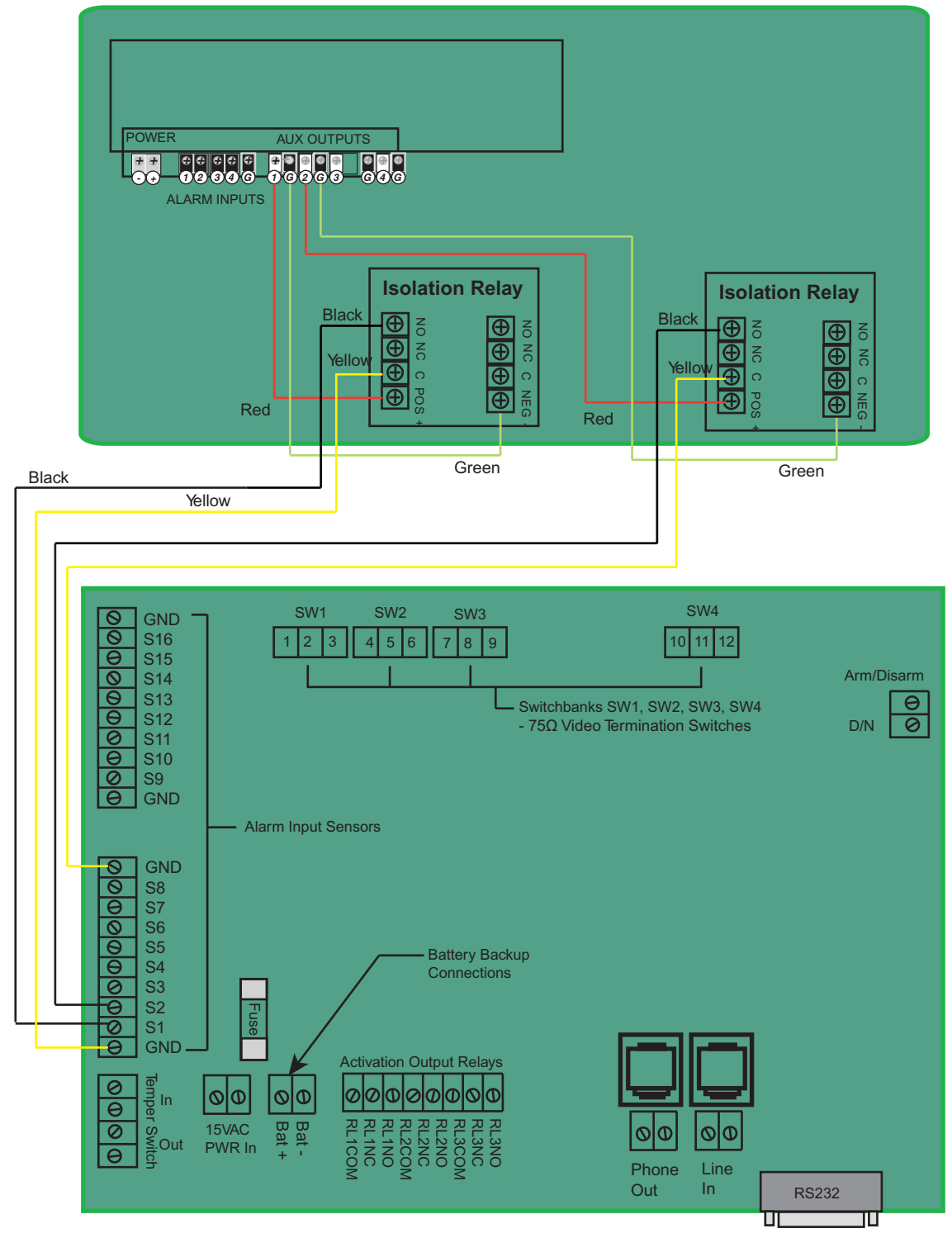

4 Connect Phone Line In and Power Supply

The power supply must be hardwired into the OzLine 12CS:
Power lead to (+)
Ground to (-)

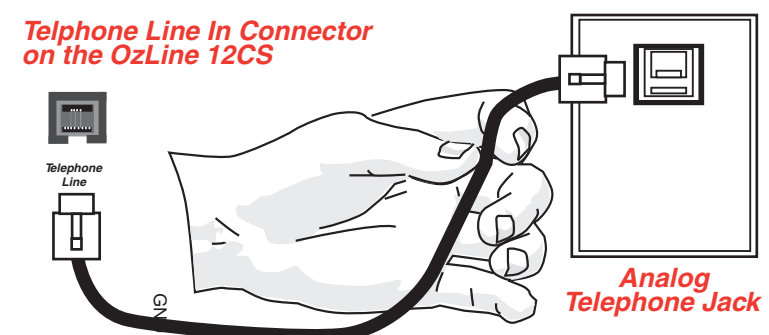
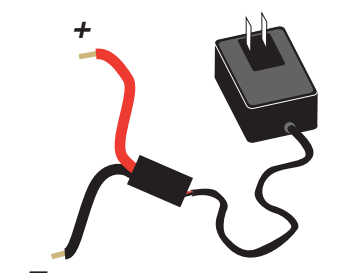

5 Connect Cameras and an Optional External Monitor

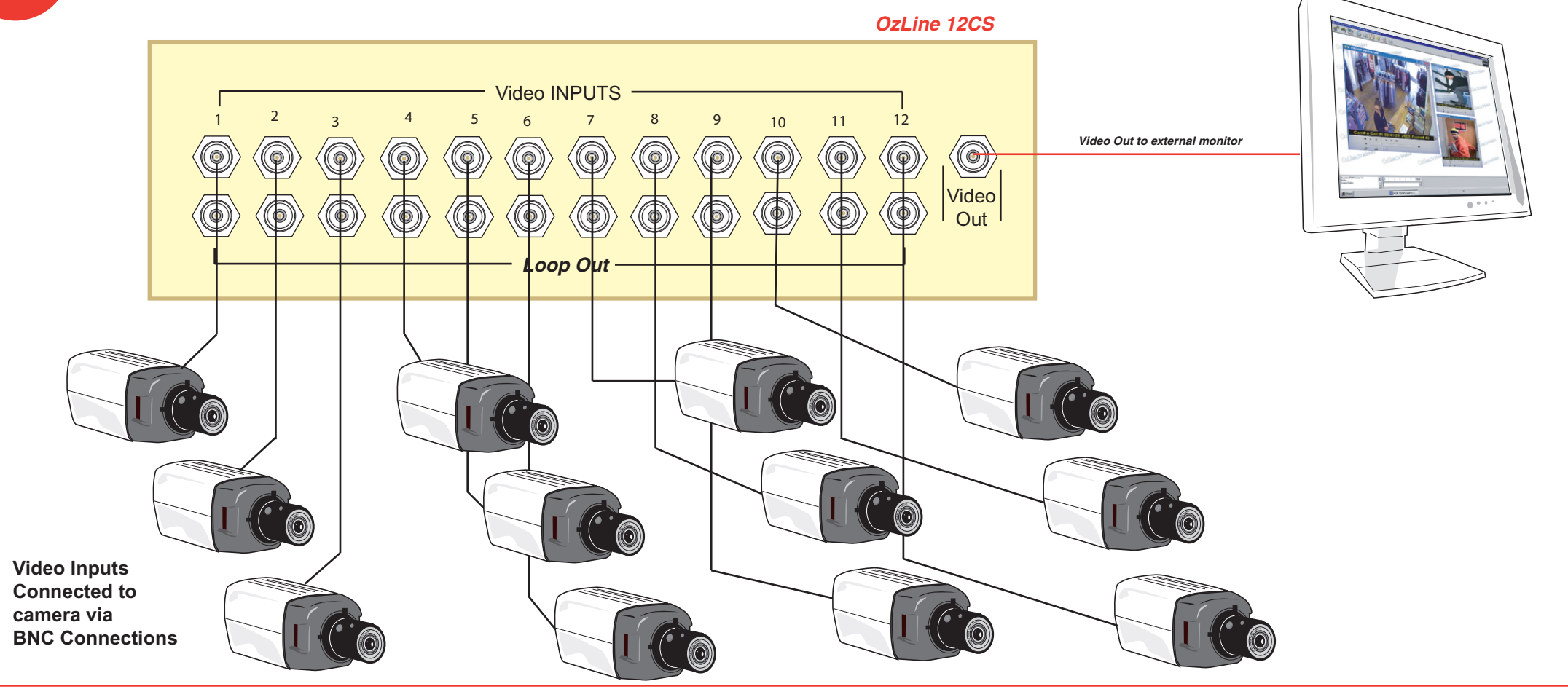

6 Connect with Central Station

Follow these steps to add video services such as visual verification, video open/close reports and OzMail notification.

- Contact your central station account manager (if central station is not OzVision Compatible, please have them contact OzVision).
- Inform the central station what services will be used.
- Provide the central station with the telephone number of the unit, as well as which sensor is associated with each camera.
- Provide the central station with the buffer parameters (length of the pre and post alarm) for the video event.
- Send signals from each zone to the central station to verify that signals are being properly received.

7 Install the Software (OPTIONAL)

OzVision's Control Center Software allows your customer to dial-in to the OzLine 4CS unit and view live video. Confirm that the computer meets the minimum hardware requirements and follow the on-screen instructions. This software may be installed on multiple computers by your customer.



Please Note:
A standard modem connection is required for the computer on which the software is to be installed.

DSL and Cable modem connections are currently not supported.

Contact Information

For updated wiring and specific panel instructions and additional questions on installing the OzLine 4CS, please contact OzVision.

OzVision, Inc.
400 West Cummings Park
Suite 3775
Woburn, MA 01801

1-800-385-2317
1-781-932-6900
www.ozvision.com
support@ozvision.com